

# Segmented Circle

inspired by NQM Collection Artist

Quilt: *Segmented Circle* by Cassandra Ireland Beaver



## Welcome Back!

Welcome to the Block of the Month Club! Round 3 will run January - December 2021.

Blocks are released as PDF patterns at Noon CST on the 1st of each month to both the FB group page, and the website: [QuiltMuseum.org/BlockOfTheMonth](https://QuiltMuseum.org/BlockOfTheMonth)

Block size has increased this Round - they will be trimmed to 12.5" x 12.5" each month and finish at 12" x 12".

As the Museum celebrates its 30th anniversary in 2021, blocks created by guest designers will be inspired by museum exhibits, programs & themes.

Finished Round 3 quilts that use all 12 blocks will be eligible for an exclusive custom label. Using the suggested layout is not required to receive a label.

We'll be using a Quilt-As-You-Go method for Round 3.

### **Quilt-As-You-Go (QAYG)**

A process of layering the top, batting and backing, then quilting each block individually before it is joined together into a finished quilt. It can relieve the stress of wrangling a large quilt through the sewing machine when quilting. As each block is quilted along the way, once they are joined together the quilt is already quilted and just needs binding!

There are many ways to accomplish QAYG, but we will be following the joining method from Marianne at [TheQuiltingEdge.com](https://TheQuiltingEdge.com) (Instagram @MariQuilts).

Fabric requirements will be for the suggested layout and QAYG joining method. Feel free to use other methods in creating your quilt if desired. See website for details on layout and fabric.

#NQMblockofthemoth

**Support the Museum!**



## Featured Artist: Cassandra Ireland Beaver

Cassandra Ireland Beaver



Cassandra is a pattern designer, quilting educator, and blogger based in west-central Ohio. She uses her training in art and theatrical design to create work that merges modern, traditional, and art quilting aesthetics. Cassandra's award-winning quilts draw inspiration from nature, architecture, and art. Her quilt "Infused Plaid", and three of her modern mini quilts reside in the collection of the National Quilt Museum.

**Blog:** <http://thenotsodramaticlife.com>

**Instagram:** @cassandra.beaver



## Sample Block: Segmented Circle



Sample by Cassandra Ireland Beaver

### Supplies

- Fat quarter of background fabric (blue)
- 6" Square Orange
- 6" Square Yellow
- 5" x 10" Rectangle Pink
- One 15" square backing fabric
- One 15" square batting

Thread to match each color in the quilt.  
Ideally for each non-background color you would use 28wt thread in the top and matching 50wt thread in the bobbin. 50wt thread is used for both the top and bobbin thread for the background areas. If you cannot obtain 28wt thread, 40wt or 50wt thread will work as well.

- Size 14 Topstitch needle (if using 28wt thread)

### Cutting

- From orange fabric cut one rectangle 5½" x 5¾"
- From yellow fabric cut one rectangle 4" x 5¾"
- From pink fabric cut one rectangle 3¾" x 9¾"
- From Blue background fabric cut:  
One 13" square  
One 1-¼" x 5¾" rectangle  
One 1-¼" x 9¾" rectangle



# Assembly: Piece the Top Block

1. Arrange the cut pieces, except for the 13" background square, as shown.

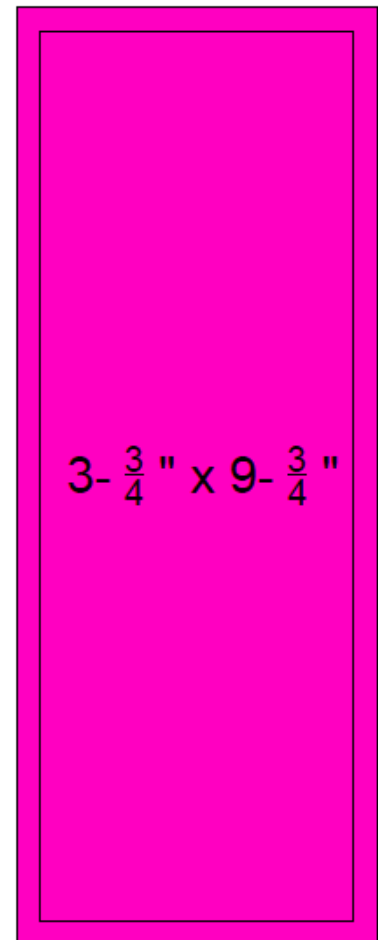
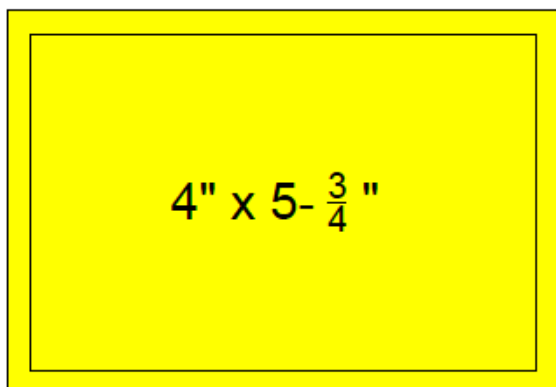
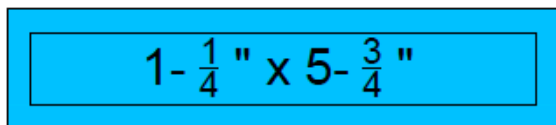
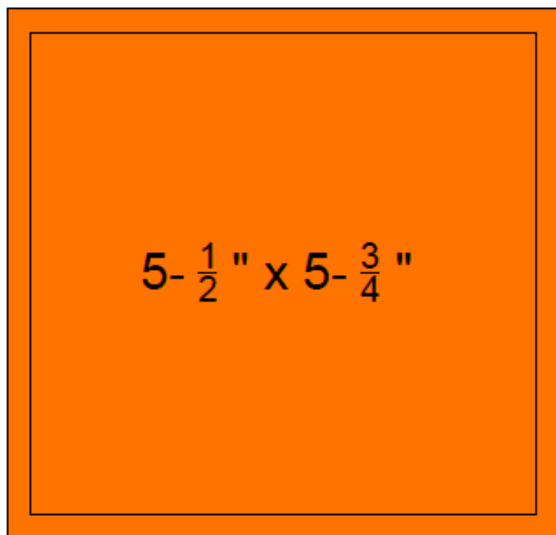



# Assembly: Piece the Top Block

2. Stitch the orange rectangle to the short background rectangle to the yellow rectangle.  
Stitch the long background rectangle to the pink rectangle.

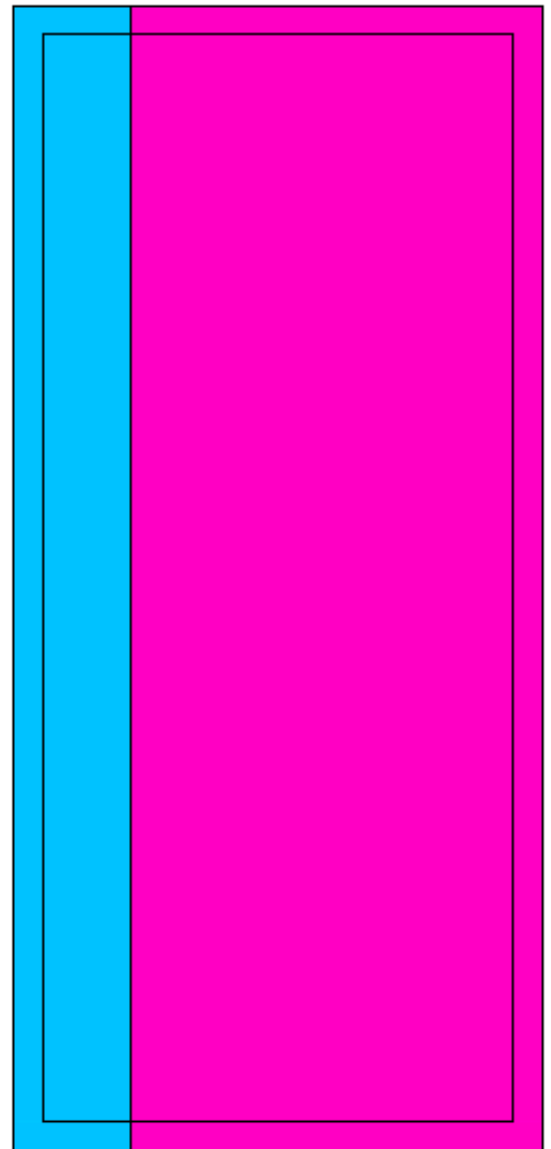
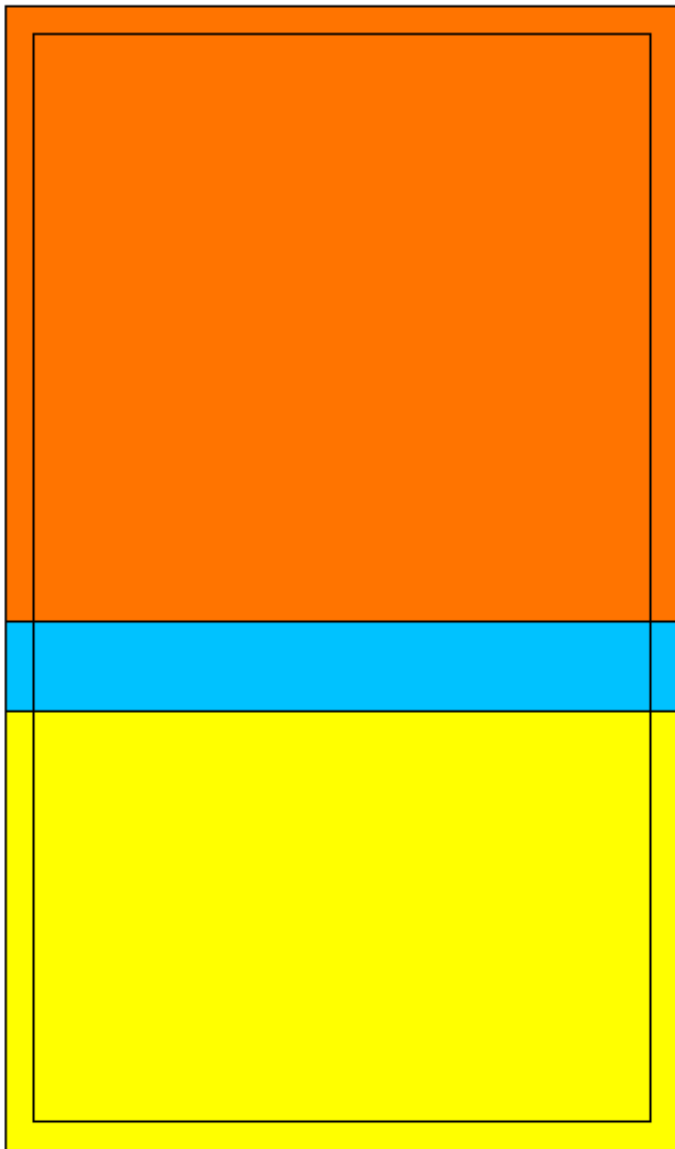



# Assembly: Piece the Top Block

3. Stitch the orange and yellow unit to the pink unit as shown.  
Print and cut out templates on page 20.

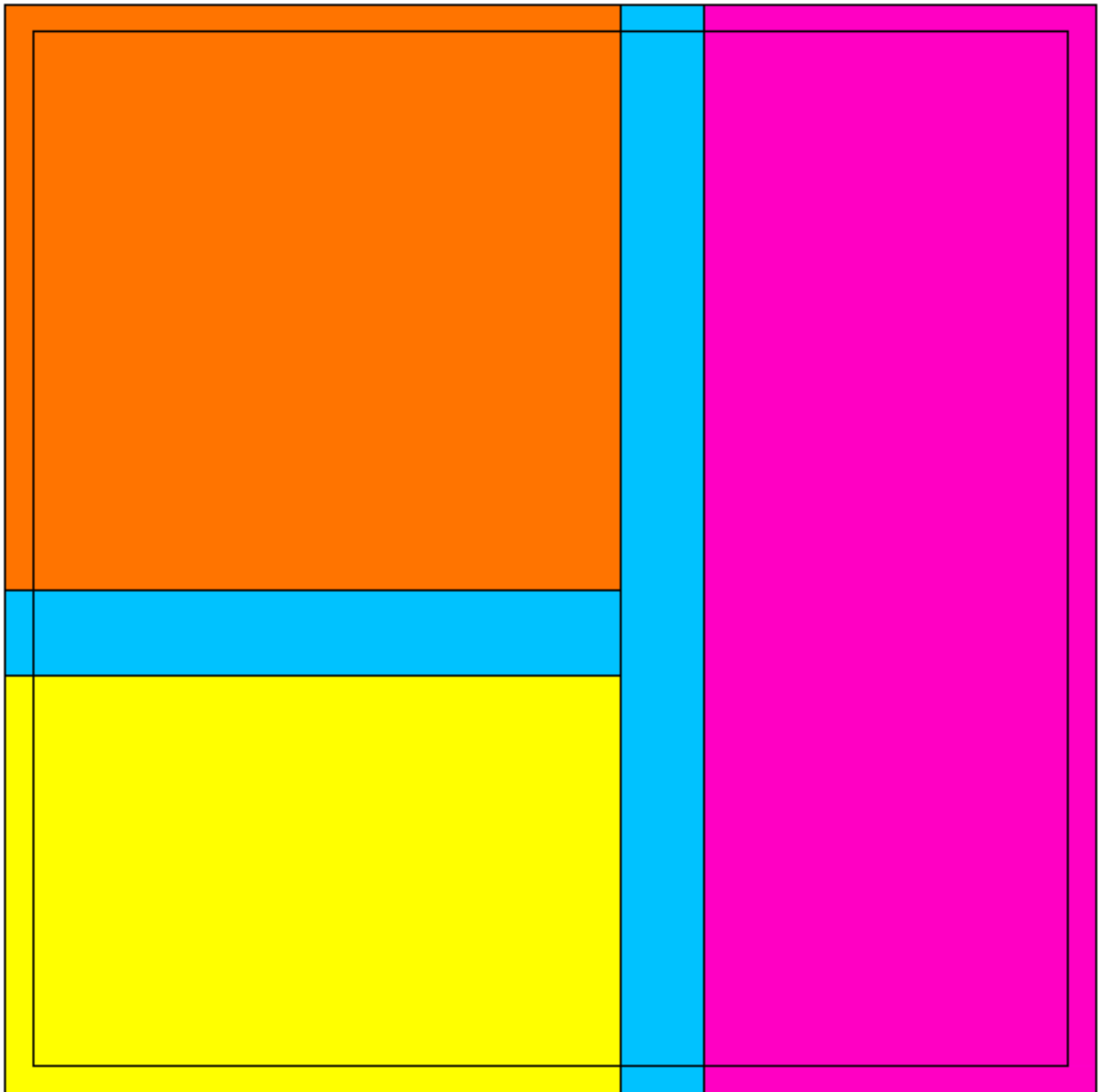



# Assembly: Piece the Top Block

**NOTE:** Take your time folding, tracing, and cutting the inner and outer circles. The success of your block depends on accurately cut pieces.

4. Fold the orange/yellow/pink unit in half horizontally. Press. Fold the unit vertically. Do not unfold.

Place the convex Inner Template on the folded material with the straight edges of the template aligned with the folded edges. Carefully trace the curved line with a fabric pen. Remove the template.

Pin the layers together away from the line to prevent shifting while cutting. Carefully cut along the drawn line. Unfold the piece, keeping the creases to use as construction indicators.

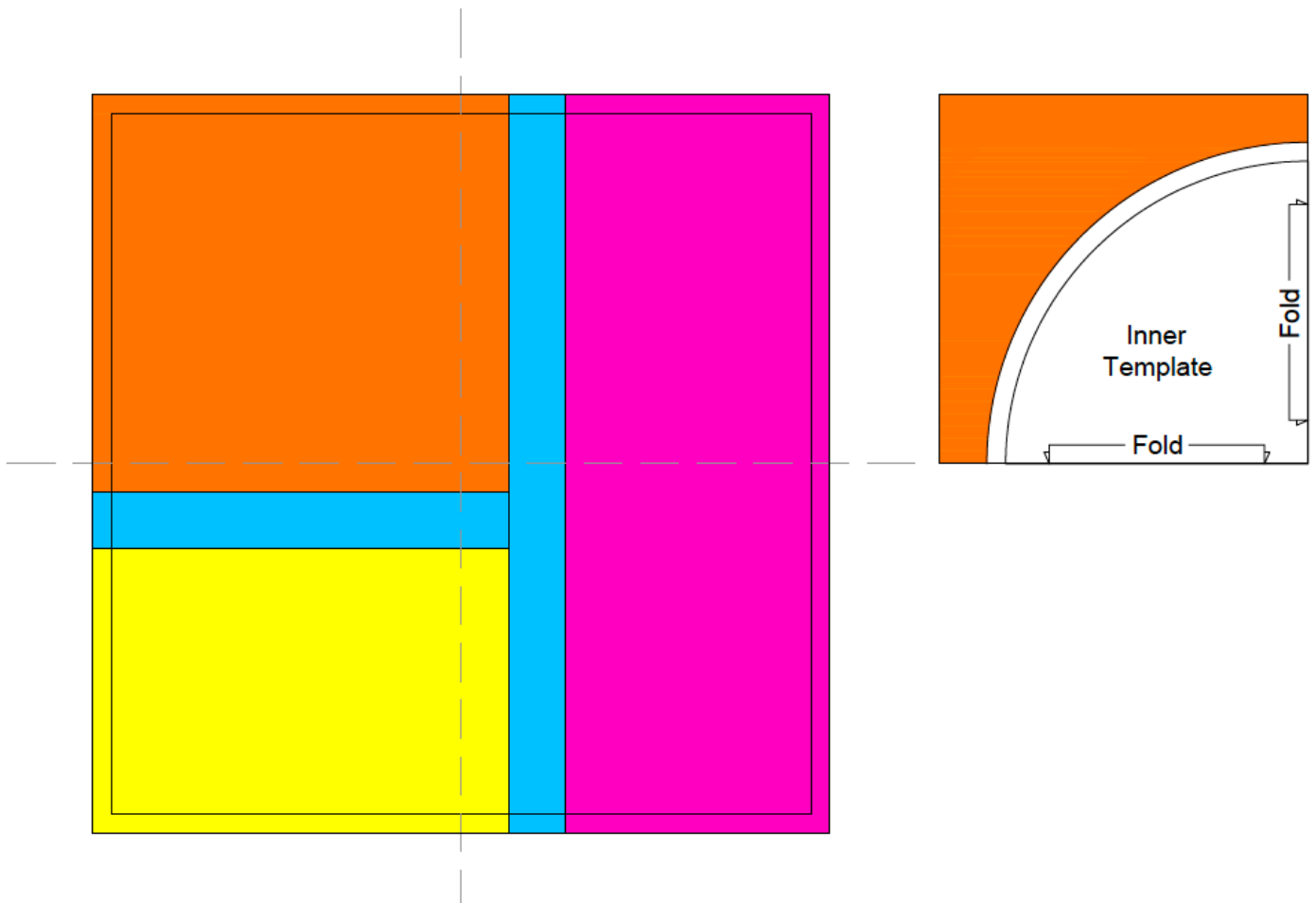





## Assembly: Piece the Top Block

5. Fold the 13" background square in half horizontally. Press. Fold in half vertically. Press. Do not unfold. Place the concave Outer Template on the folded fabric with the indicated edges on the folds. Trace the curved line with a fabric pen. Remove template. Pin the layers together away from the drawn line to prevent shifting while cutting. Carefully cut along the drawn line. Unfold the piece, keeping the creases to use as construction indicators.

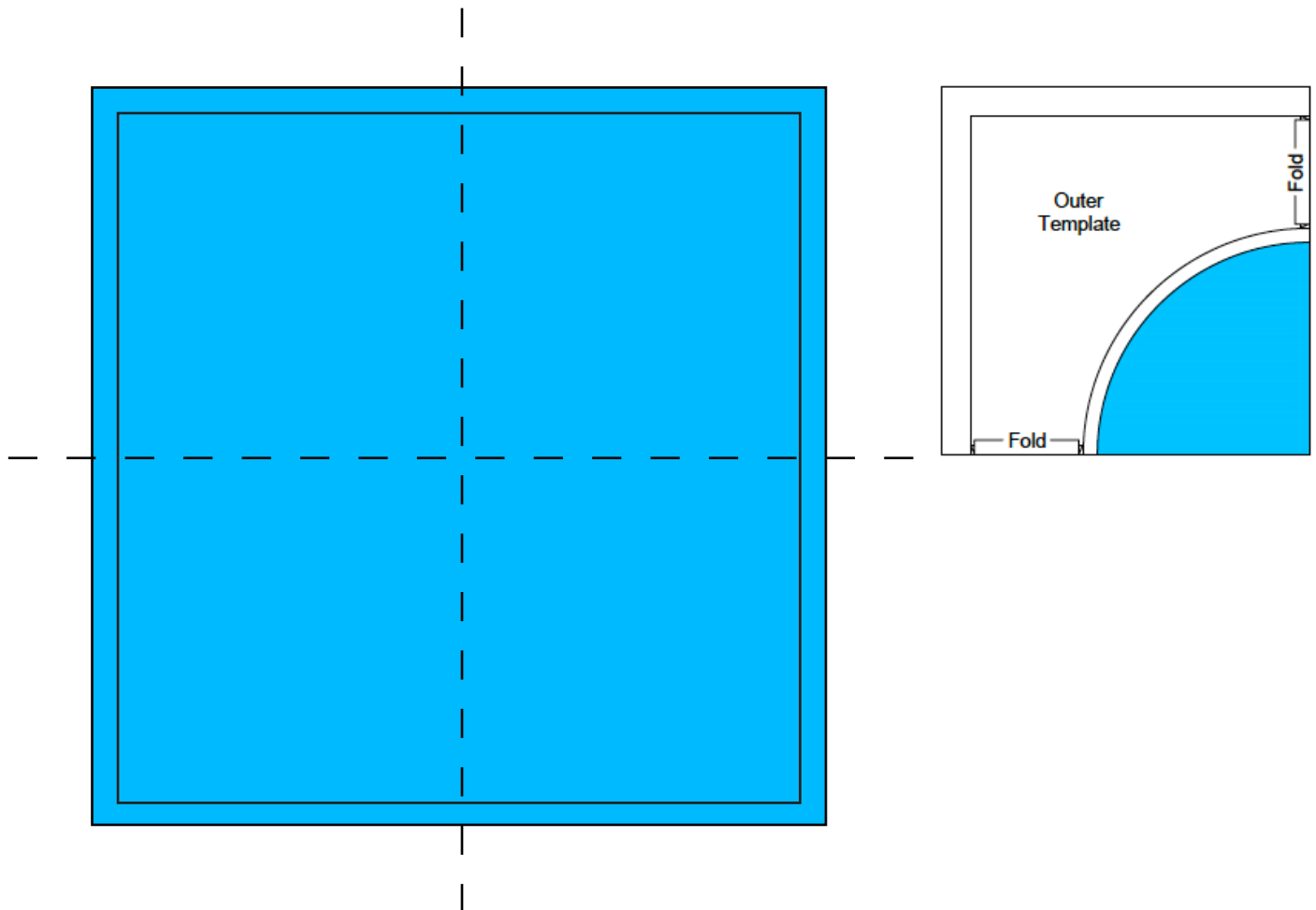



# Assembly: Piece the Top Block

- Using a removable fabric pen, mark the crease lines on both the inner and outer circle A, B, C, and D as shown.

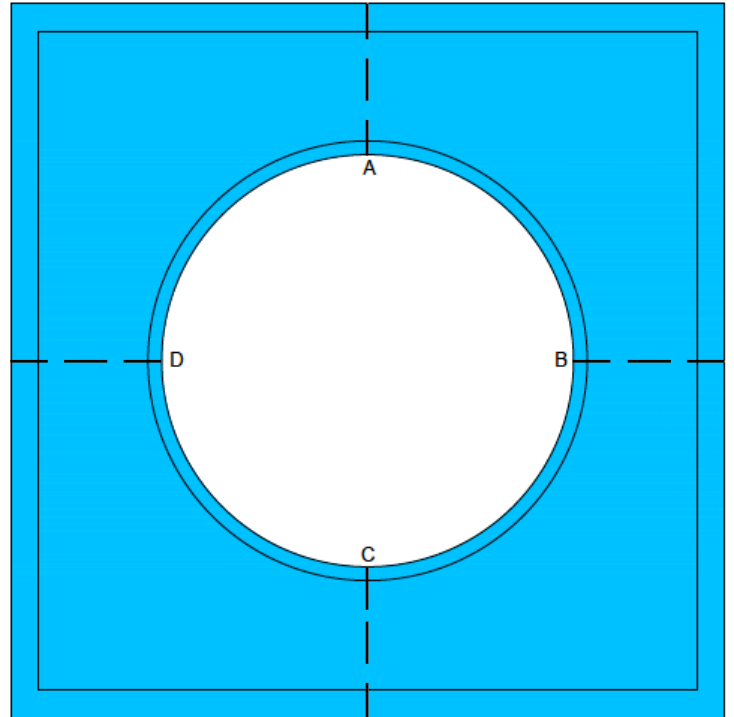
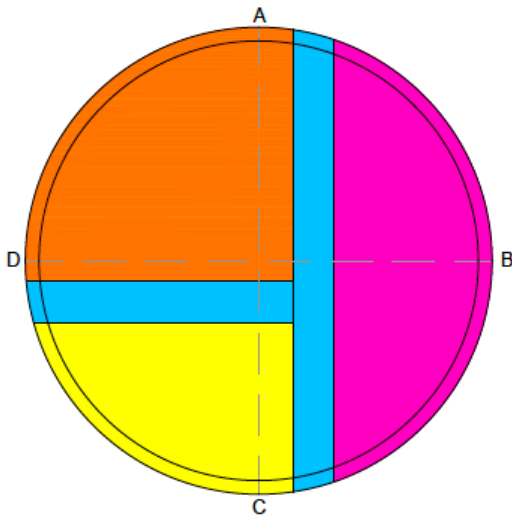



# Assembly: Piece the Top Block

7. On both the inner and outer circles fold the pieces in half diagonally so point A meets point B and point C meets point D. Press a crease in this line. Unfold. Fold each unit in half diagonally the other direction so point A meets point D and point B meets point C. Press a crease in this line. Unfold.

**NOTE:** Handle the pieces carefully, especially the background piece, to avoid stretching the cut circles.

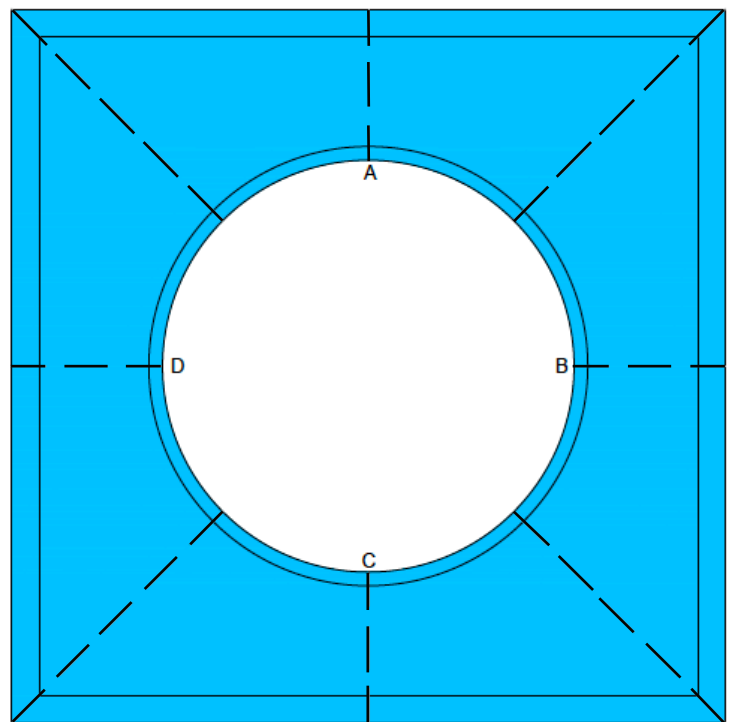
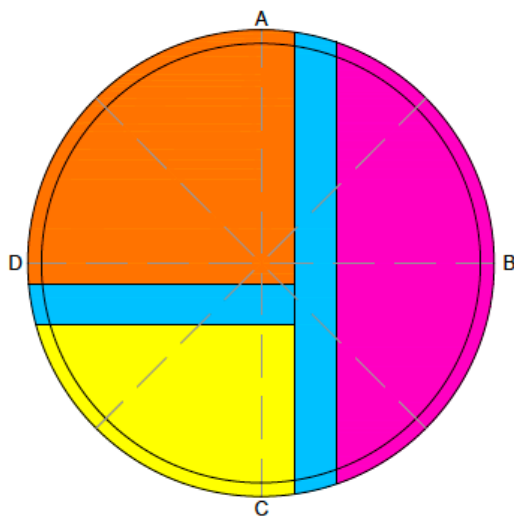



# Assembly: Piece the Top Block

8. With the right sides of the fabrics together, match point A on the outer circle to point A on the inner circle. Pin with the cut edges aligned. Do the same with points B, C, and D. Align and pin the pressed diagonal creases. Add pins between the crease lines as needed to ensure the cut edges of the circles are aligned.

The outer corners of blue background fabric will be scrunched into the center as you pin the pieces together.

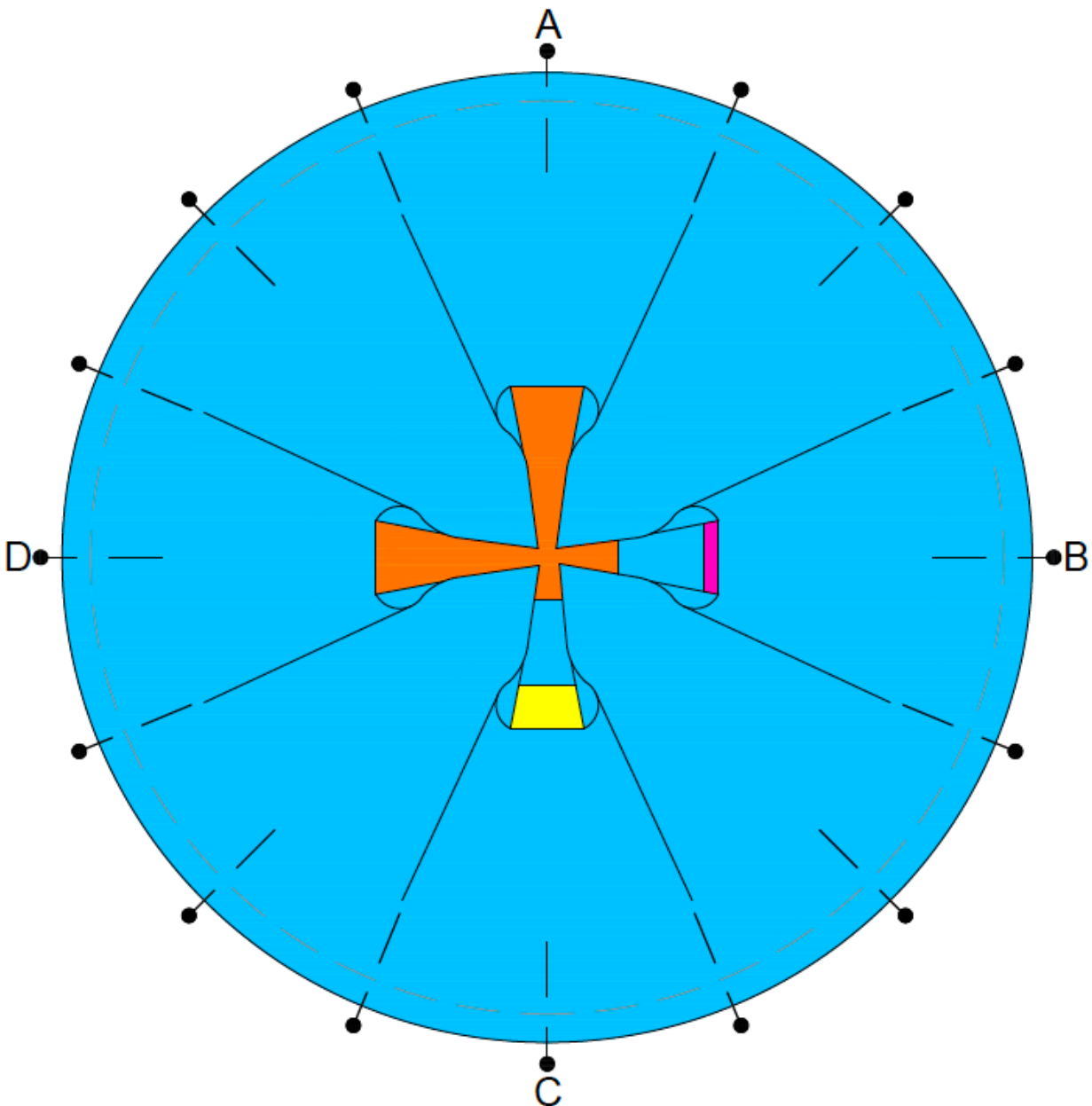



## Assembly: Piece the Top Block

9. With the background fabric on top, use an accurate  $1/4$ " seam to machine piece the circle. Press the seam allowance toward the background fabric.

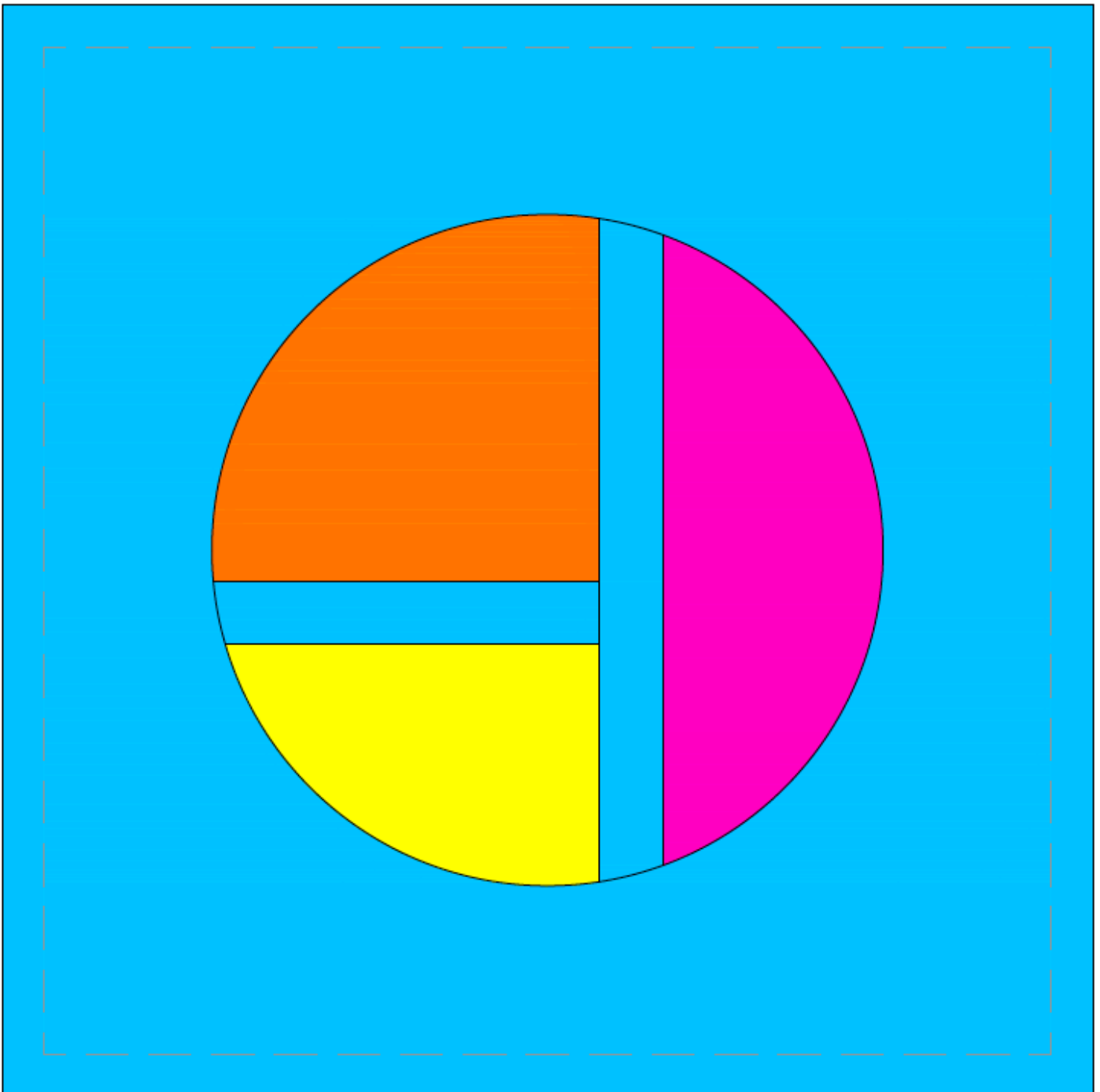



# Quilting

Layer the quilt backing, batting, and pieced quilt top. Baste.

Thread the sewing machine in orange thread using 28wt thread in the top and 50wt thread in the bobbin. Use the Top Stitching needle to quilt.

**NOTE:** For the horizontal lines, I suggest quilting from the center of the quilt outward. Since the quilting is a dominant design element, avoid back stitching to lock the quilting in. Instead, use a lock stitch or bring the bobbin thread up to the top of the quilt, knot, and bury the thread.

10. Mark and stitch a line at the top and bottom of the orange section of piecing. To mark lines, you may use masking tape or a removable fabric pen.

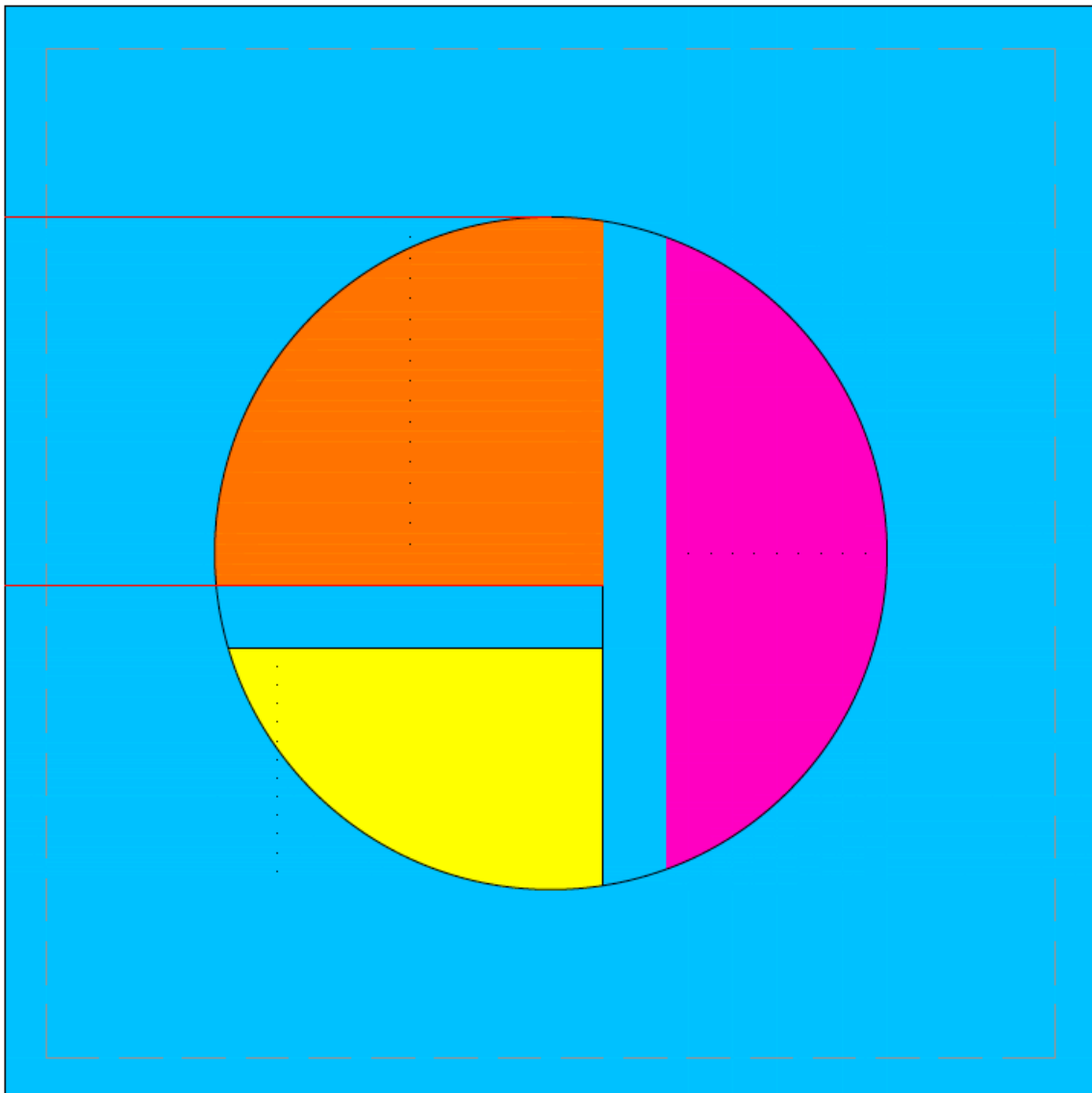



# Quilting

11. Mark 1" increments from the bottom stitched line. At the top, you will have one space that is approximately 1/2". Stitch.

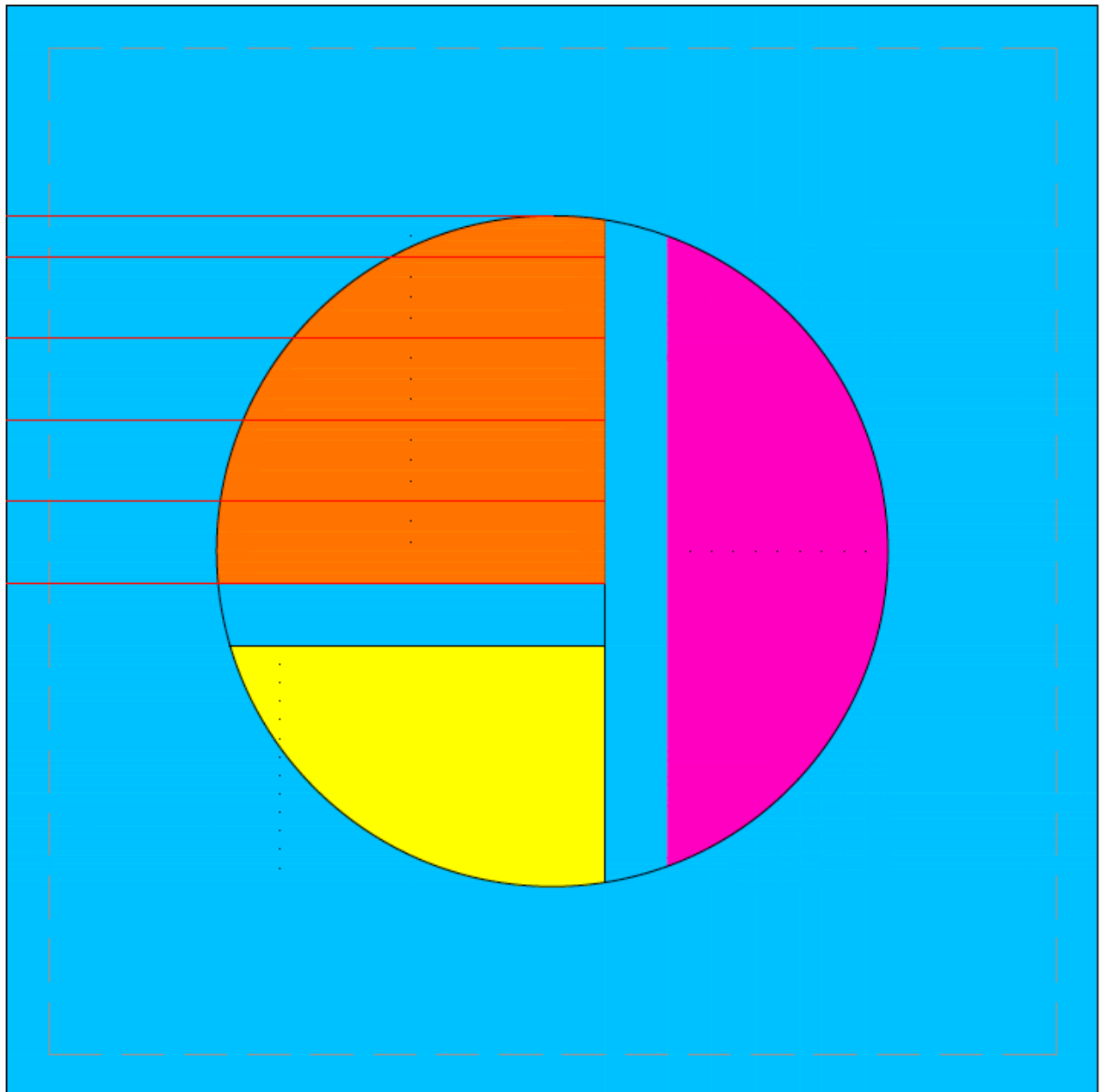



# Quilting

12. Stitch halfway between the 1" increments to create 1/2" spaces.

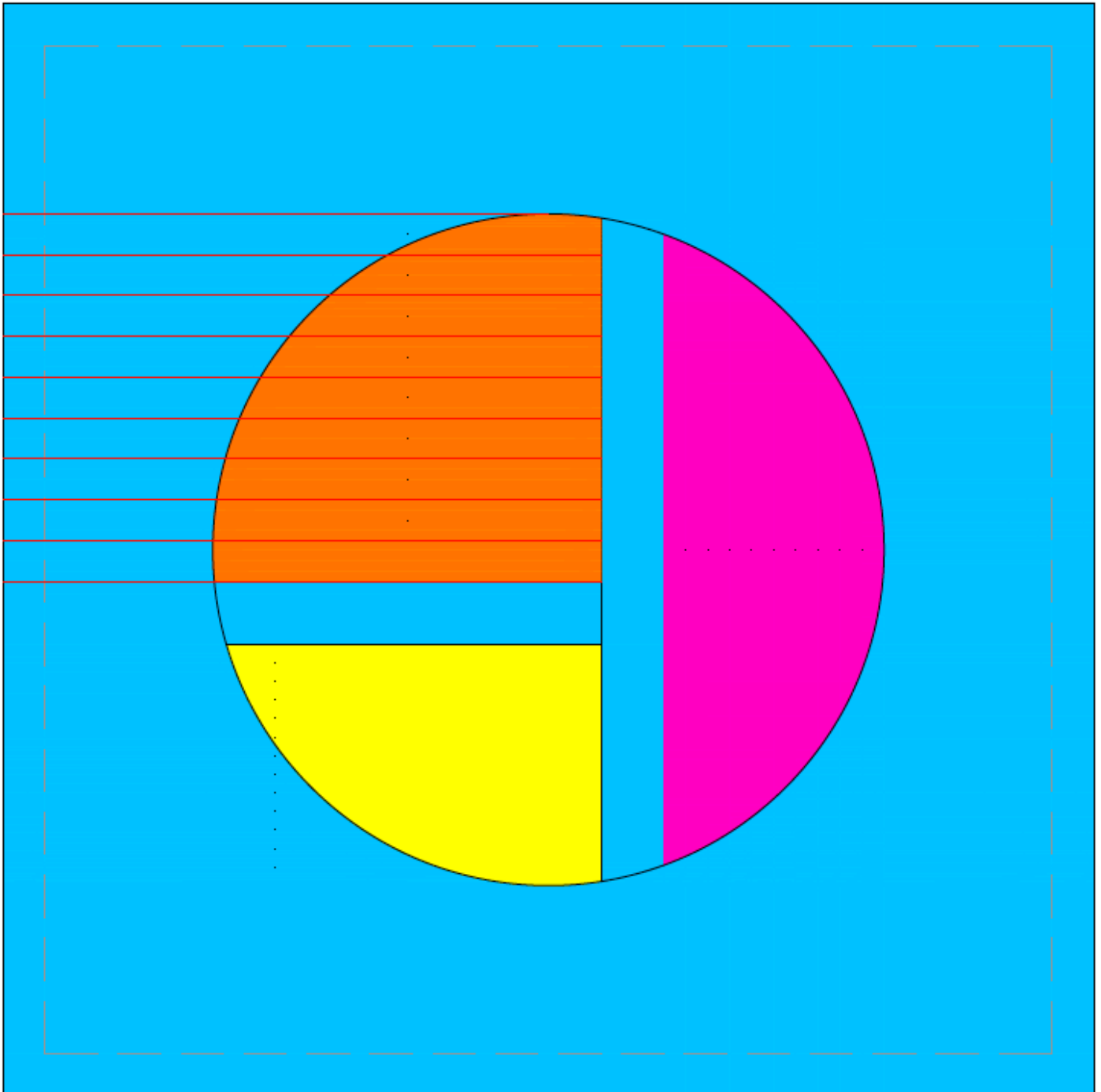





# Quilting

13. Stitch halfway between the previously quilted lines to create 1/4" spaces.

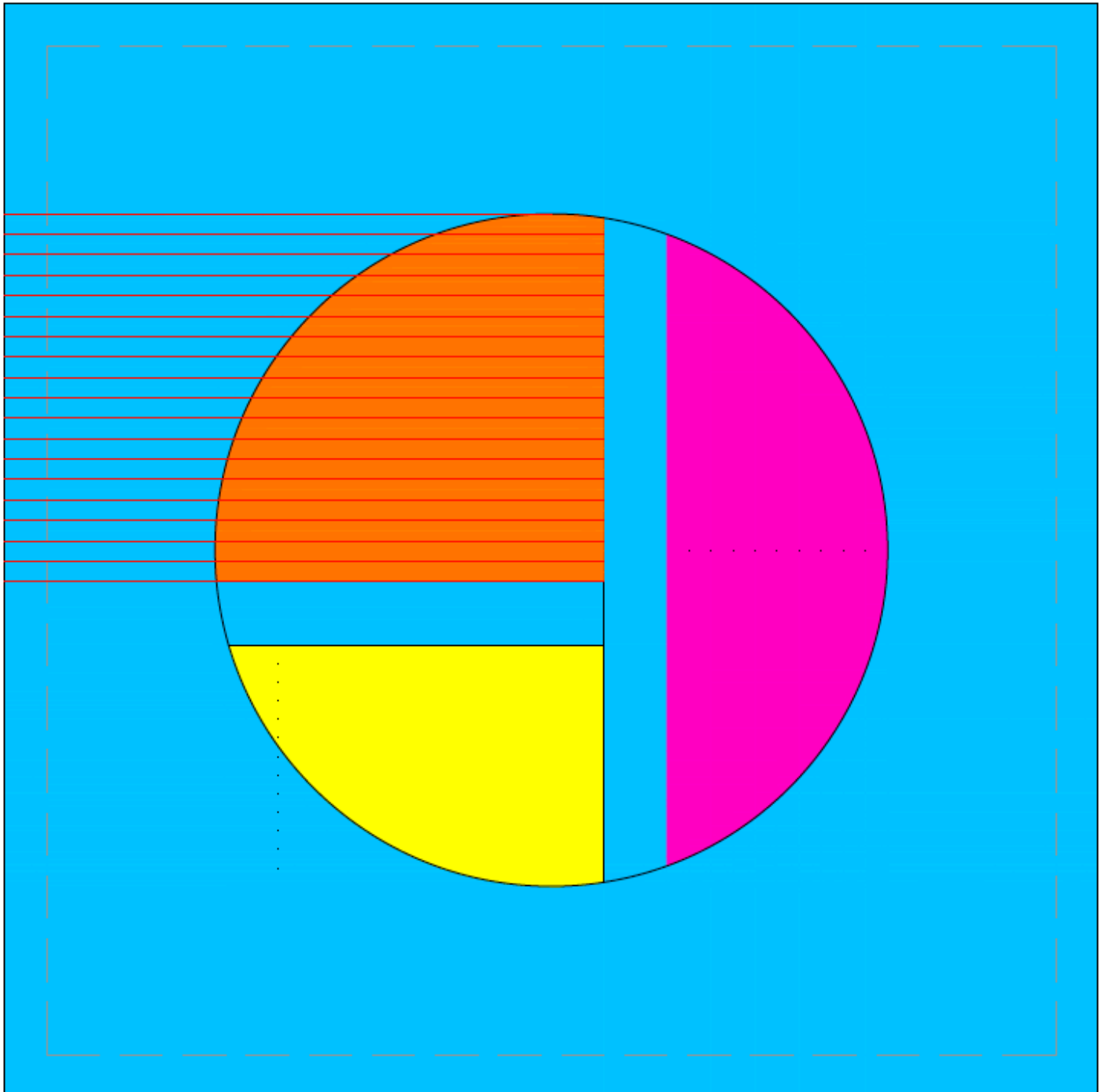



# Quilting

14. Stitch halfway between the previously quilted lines to create 1/8" spaces.

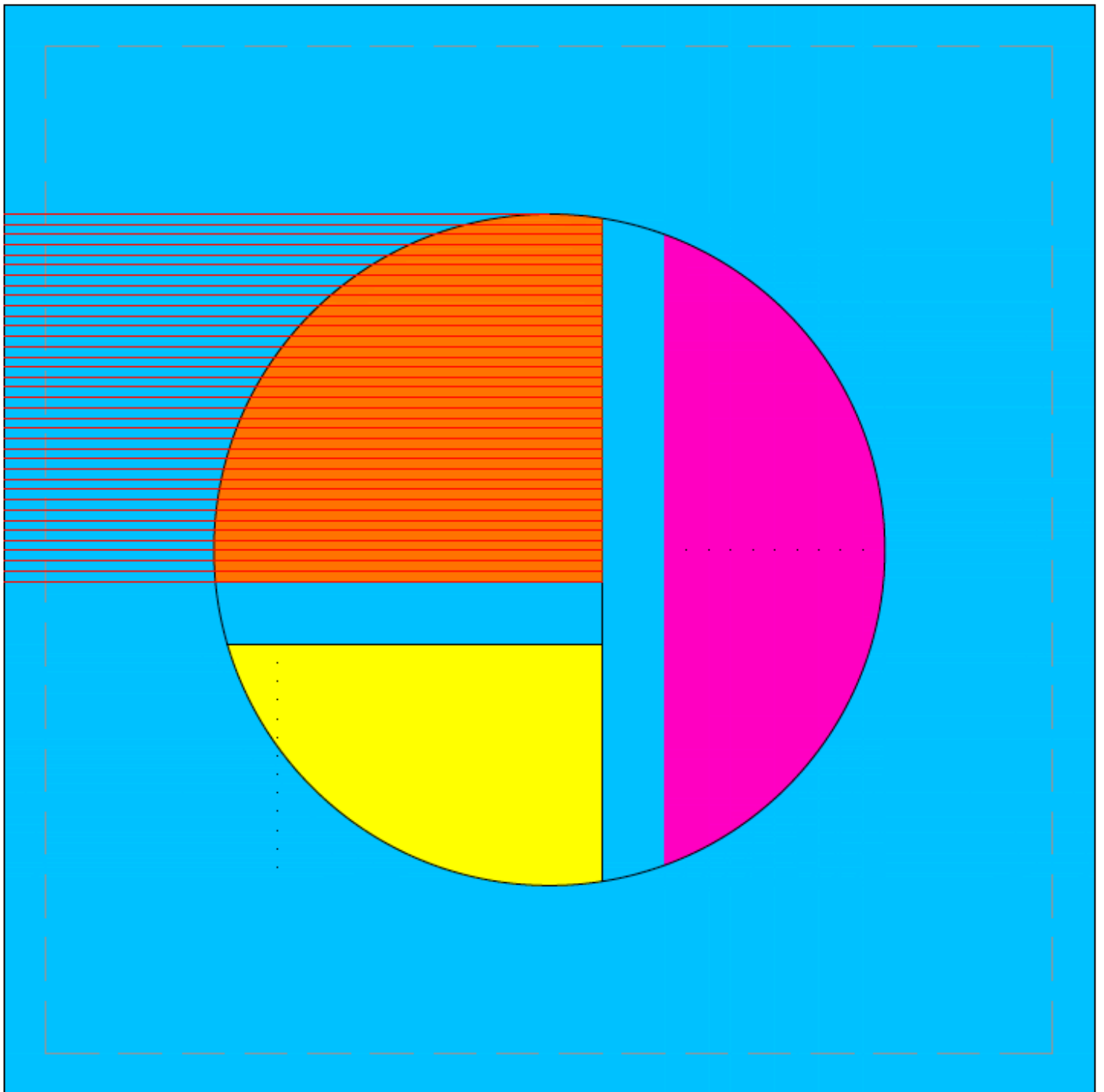



# Quilting

15. Repeat steps 10-14 to quilt the yellow and pink area of the quilt as shown. Use yellow thread for the yellow area and pink thread for the pink area. Using blue 50wt thread in both the top and bobbin, quilt the background using the same method to complete the block.
16. Trim the block to  $12\frac{1}{2}$ " x  $12\frac{1}{2}$ " square.

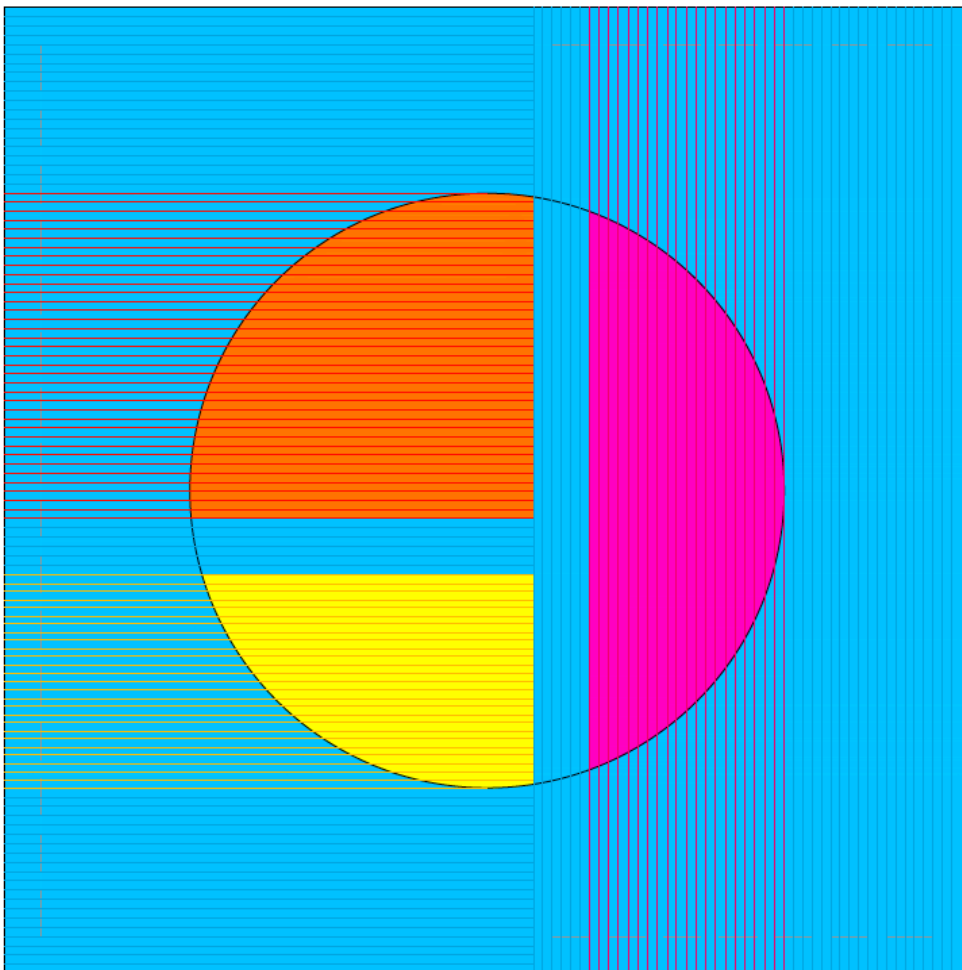

Finished?  
Fantastic!

